

Stabilization and optimization of a two-stage dc SQUID coupled to a high Q resonator

Andrea Vinante^a, Michele Bonaldi^b, Paolo Falferi^b, Massimo Cerdonio^c, Renato Mezzena^a, Giovanni Andrea Prodi^a and Stefano Vitale^a

^aDipartimento di Fisica, Università di Trento and INFN, Gruppo Collegato di Trento, Sezione di Padova, I-38050, Povo, Trento, Italy

^bCentro di Fisica degli Stati Aggregati and INFN, Gruppo Collegato di Trento, Sezione di Padova, I-38050, Povo, Trento, Italy

^cDipartimento di Fisica, Università di Padova and INFN, Sezione di Padova, Via Marzolo 8, I-35131, Padova, Italy

Abstract

A two-stage dc SQUID is strongly coupled to an electrical resonator at 1.6 kHz with quality factor $Q=1.1\times 10^6$ in order to simulate the behaviour of the SQUID on a resonant gravitational wave detector. A capacitive damping network is successfully employed in order to avoid the instabilities due to the real part of the SQUID dynamic input impedance. The coupled energy resolution is $300 \hbar$ at 4.2 K, scales with temperature, and is not significantly worsened by the coupling to the resonator and by the damping network.

Keywords: dc SQUID, High Q resonator, Gravitational wave detector

Corresponding Author: Andrea Vinante, Dipartimento di Fisica, Via Sommarive 14, I-38050, Povo (TN), Italy. E-mail: vinante@science.unitn.it. Fax: +39 0461 881680

1. Introduction

One of the experiments that requires the highest possible sensitivity of a dc SQUID is the detection of gravitational waves (GW) by means of a cryogenic resonant detector. Such system [1] is basically a massive (3 tons) mechanical resonator with a frequency of about 1 kHz and a very high quality factor ($Q > 10^6$), that constitutes the GW sensing element. The motion of the resonator is converted by means of an electromechanical transducer into an electrical signal, that is usually detected by a low noise dc SQUID amplifier. Up to now the best sensitivity of a SQUID actually operated on a GW detector was obtained in the AURIGA experiment [2], where a commercial dc SQUID [3] was operated with an energy resolution of about $4000 \hbar$, quite close to the specifications. Unfortunately this noise level, basically limited by the room temperature electronics noise [4], is higher by more than two order of magnitude with respect to the best device described in literature [5].

Since the overall detector sensitivity is finally limited by the noise energy of the amplifier [6], a crucial step is to demonstrate that a high sensitivity SQUID can be operated in the typical working conditions of a GW detector without a significant increase in the noise. Indeed, when a SQUID is tightly coupled to a high Q resonant load such as a GW detector, some additional problems arise. Perhaps the most serious one is the modification of the resonator quality factor due to the real part of the SQUID dynamic input impedance. Since the latter can take negative values, the overall quality factor itself can be negative, driving the resonator into instability [7]. Thus it may be impossible to optimize the noise without getting into instability.

In this report we describe a two-stage SQUID system that was developed for working on the gravitational wave detector AURIGA with a noise energy of the order of $100 \hbar$. We employ an electrical resonator in the kHz frequency range with a quality factor higher than 10^6 to simulate the input load of SQUID that is operated on a resonant GW detector. Then we describe a method to stabilize the SQUID-resonator system without a significant increase in the noise.

2. System description

A detailed scheme and a description of the noise performance of the uncoupled SQUID system down to 50 mK has been reported in a previous article [8]. A simplified circuit diagram is shown in Fig. 1. In order to improve the SQUID sensitivity, by making negligible the noise added from the room temperature electronics, we employ a two-stage SQUID readout, in which the first SQUID is the signal sensor and the second SQUID operates as low noise amplifier of the sensor output signal. Both sensor and amplifier chips are manufactured by Quantum Design [3]. The SQUIDs are placed in separate superconducting shields and are connected to the room temperature electronics through separate cables in order to avoid any stray crosstalk between the two sets of wires. The SQUID sensor, that is biased through a battery-powered current box, is not modulated and its output voltage is fed to the SQUID amplifier through a matching resistor, $R_m = 2.2 \Omega$. The SQUID amplifier is read out by a standard manufacturer electronics with a 500 kHz modulation scheme. The system is operated in conventional flux locked loop, with the output signal from the amplifier electronics sent through a 1-pole integrator and fed back to the SQUID sensor through a feedback coil. Both SQUIDs are then locked through the same loop. The maximum bandwidth of the system in closed loop mode is limited by various filtering stages to about 50 kHz, and the maximum slew rate is about $2 \times 10^4 \Phi_0/s$. The input coil inductance is $L_i = 1.64 \mu\text{H}$, the SQUID-input coil and SQUID-feedback coil mutual inductances are respectively $M_i = 10.7 \text{ nH}$ and $M_f = 1.60 \text{ nH}$.

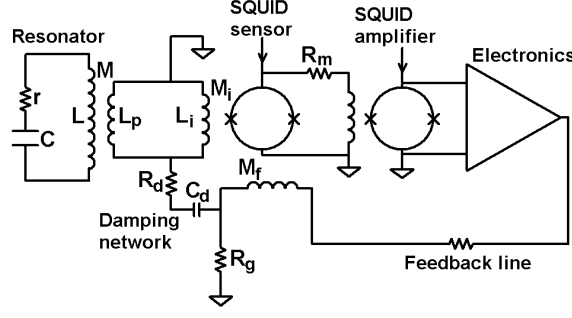

Fig. 1: Circuit diagram of the closed loop two-stage dc SQUID coupled to the high Q electrical resonator. The capacitive damping network is also shown.

The electrical resonator employed in this experiment is also schematized in Fig. 1. It is made of a superconducting coil $L=0.554$ H and a teflon capacitor $C=19.1$ nF, both enclosed in two separate superconducting houses to reduce eddy current dissipation [4,9]. The resonator is coupled to the SQUID through a strongly coupled superconducting transformer whose elements are a pick-up coil $L_p=2.8$ μ H and the SQUID input coil L_i . The mutual inductance between the main coil L and the pick-up coil L_p is $M=0.59$ mH and the coupling factor is $k^2=M^2/LL_p=0.22$. The effective inductance of the resonator coil coupled to the matching transformer is given by $L_e=L-M^2/(L_i+L_p)=0.475$ H. The intrinsic resonance frequency and quality factor of the resonator are respectively $\omega_0=\omega_0/2\pi=1671.4$ Hz and $Q_{\text{int}}=\omega_0 L_e/r=1.08\times 10^6$ [10].

3. Resonator stabilization

To measure the quality factor the resonator is excited and then allowed to decay freely. The signal from the SQUID is sent to a lock-in amplifier with reference frequency $\omega_{\text{ref}}\approx\omega_0$ and the measured magnitude is sampled. The quality factor is estimated as $Q=\pi\omega_0 t$, where t is decay time constant evaluated by an exponential fit of the sampled magnitude versus time.

In general the quality factor of the resonator is modified by the presence of the strongly coupled SQUID. This effect is due to the real part of the input impedance of the SQUID [7], and depends both on the bias current and the dc flux of the SQUID sensor. In particular there are working points where the total Q is negative and the resonator is driven into instability. By changing the working point the value of $1/Q$ oscillates indicatively between the extreme values $1/Q\approx\pm 10^{-4}$. The contribution of the intrinsic dissipation, $1/Q_{\text{int}}\approx 10^{-6}$, is thus practically negligible and the quality factor is almost completely determined by the SQUID.

In order to avoid the negative Q instabilities due to the SQUID input impedance we implement a cold damping network. The idea is to reduce the quality factor in order to counterbalance the negative $1/Q$ terms related to the SQUID input impedance. Reducing Q , and hence the decay time constant t , is also useful to reduce the time of a measurement of the resonator noise [10].

To realize the cold damping network we put a capacitor $C_d=100$ pF between the input coil and the feedback coil, as schematized in Fig. 1. The other side of the input coil is grounded, while a resistor R_g is put between the feedback coil and the ground. When the SQUID is operated in flux locked loop mode, a small fraction $R_g\omega C_d\ll 1$ of the feedback current flows to ground through the capacitor C_d and the input circuit with a phase shift of 90° , simulating the dynamical effect of a resistor in the input circuit. We put also an additional resistor $R_d=0.51$ M Ω in series to C_d to avoid high frequency shorting between input and feedback coil.

Following the model in Fig. 1 the equivalent change of impedance in series to the resonator due to the damping network can be calculated. The real part of this additional impedance divided by $\omega_0 L_e$ gives the following contribution of the damping network to the inverse of the quality factor:

$$D\left(\frac{1}{Q}\right) = bR_g \quad (1)$$

where:

$$b = \left(\frac{M}{L_i + L_p}\right)^2 \frac{M_i L_i}{M_f L_e} \frac{\omega_0 C_d}{1 + (\omega_0 C_d R_d)^2} \quad (2)$$

In order to test Eq. (1) we measure $1/Q$ as function of R_g . The experimental results are showed in Fig. 2. The data are in good agreement with the expected linear behaviour. The slope evaluated through a linear fit is $b = (3.23 \pm 0.07) \times 10^{-7} \Omega^{-1}$. This value is consistent with the expected value $b = (3.35 \pm 0.10) \times 10^{-7} \Omega^{-1}$ that is calculated through Eq. (2) after an independent measurement of all circuital parameters.

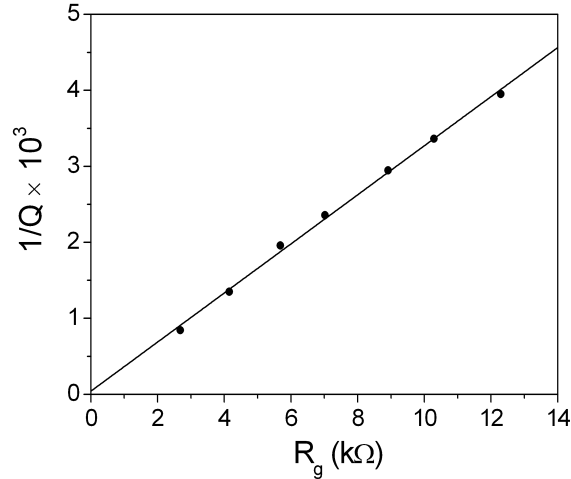

Fig. 2: Inverse of the resonator quality factor $1/Q$ as function of the ground resistor R_g . The straight line is the best linear fit to the experimental data.

4. Noise measurements

The flux noise of the SQUID coupled to the high Q resonator with the cold damping network is then measured. The output power spectrum is the superposition of the SQUID additive noise and the resonator noise. The latter is essentially a lorentzian peak centered at $n=n_0$ that dominates over the SQUID white noise over a bandwidth of about 300 Hz. The SQUID noise measurement is then performed at $n > 5$ kHz, where resonator noise is practically negligible and the power spectrum is white. To extract the noise power spectral density we use a computer based spectrum analyzer and average up to 1000 periodograms. The current and flux bias points of SQUID sensor are then changed until the averaged flux noise reaches a minimum. The coupled energy resolution is then calculated through the definition $e = S_{FF} L_i / 2M_i^2$ where S_{FF} is the flux noise power spectral density.

The behaviour of the energy resolution as function of temperature in the range 1.5 K- 4.2 K is shown in Fig. 3. The noise scales rather well with temperature within the experimental

uncertainties. Slope and intercept obtained by a linear fit in Fig. 3 are respectively $(69\pm 1) \hbar/\text{K}$ and $(11\pm 3) \hbar$. The value of the slope is reasonably close to the value predicted by Clarke-Tesche theory [11]:

$$\frac{de}{dT} = \frac{9k_B L_{\text{SQ}}}{a^2 R_{\text{SQ}}} = 54 \frac{\hbar}{\text{K}} \quad (3)$$

where $L_{\text{SQ}}=80 \text{ pH}$, $R_{\text{SQ}}=2 \Omega$, $a^2=0.87$ are respectively the manufacturer's estimates of SQUID loop inductance, Josephson junctions shunt resistance and SQUID-input coil coupling factor. Equation (3) is strictly valid only when the SQUID input coil is left open. However, when the input coil is shorted on the inductive input load L_p , the noise is expected to be only slightly reduced, at most by a factor 2 in our case [4].

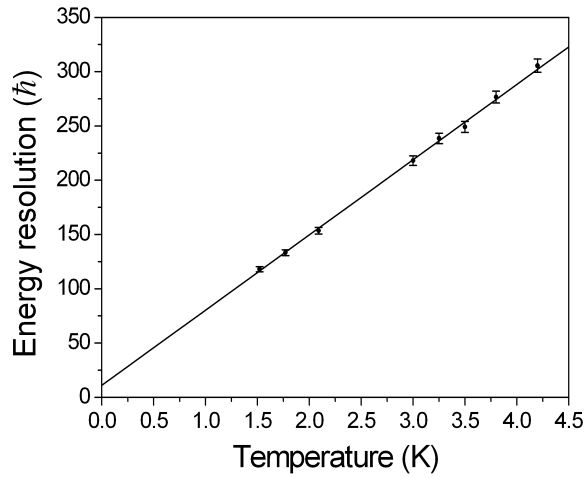

Fig. 3: Energy resolution in the white noise region of the SQUID coupled to the high Q resonator. The straight line is the best weighted linear fit to the experimental data.

At a given temperature the best flux noise doesn't depend within the error bars on the value of R_g for $R_g < 12 \text{ k}\Omega$. Indeed the Nyquist contribution of the cold damping resistors R_g and R_d to the energy resolution is estimated always smaller than $4 \hbar$ for $R_g < 12 \text{ k}\Omega$.

To check if the coupling to the resonator or the presence of the damping network increase significantly the noise we measure also the SQUID flux noise without resonator and damping network. For this purpose the coil L is removed and the SQUID is connected only to the pick-up coil L_p . The best noise at $T=4.2 \text{ K}$ is $e=(290\pm 5) \hbar$, that is equal, within the error bars, to the value obtained at $T=4.2 \text{ K}$ with the resonator coupled, $e=(295\pm 5) \hbar$. From this result we conclude that neither the presence of the high Q resonant load, nor the implementation of the cold damping network affect appreciably the energy resolution of our SQUID system.

A more detailed report on the noise measurements in the temperature range 1.5 K- 4.2 K, that will include also the measurement of the resonator noise and the estimation of the true noise temperature of the SQUID amplifier, will be published elsewhere [10].

Acknowledgements

We thank Quantum Design for providing the SQUID chips. This work was supported in part by a grant MURST-COFIN '99.

References

- [1] M. Cerdonio, M. Bonaldi, D. Carlesso, E. Cavallini, S. Caruso, A. Colombo, P. Falferi, G. Fontana, P.L. Fortini, R. Mezzena, A.Ortolan, G.A. Prodi, L.Taffarello, G. Vedovato, S. Vitale and J.P. Zendri, *Class. Quantum Grav.* 14, 1491 (1997).
- [2] J. P. Zendri et al, in: *Gravitational waves, Proceedings of the Third Edoardo Amaldi Conference*, ed. S. Meshkov (AIP Conference Proceedings, New York, 2000), p. 221-222.
- [3] *Quantum Design*, 11578 Sorrento Valley Road, Suite 30, San Diego, CA 92121-1311.
- [4] P. Falferi, M. Bonaldi, M. Cerdonio, M. Mück, R. Mezzena, A. Vinante, G.A. Prodi and S. Vitale, *J. Low Temp. Phys.* 123, 275 (2001).
- [5] P. Carelli, M. G. Castellano, G. Torrioli and R. Leoni, *Appl. Phys. Lett.* 72, 115 (1998)
- [6] R.P. Giffard, *Phys. Rev. D* 14, 2478 (1976); J.C. Price, *Phys. Rev. D* 36, 3555 (1987).
- [7] C. Hilbert and J. Clarke, *J. Low Temp. Phys.* 61, 237 (1985); P. Falferi, R. Mezzena, S. Vitale and M. Cerdonio, *Appl. Phys. Lett.* 71, 956 (1997).
- [8] R. Mezzena, A. Vinante, P. Falferi, M. Bonaldi, G.A. Prodi, S. Vitale and M. Simmonds, *Rev. Sci. Instrum.* 72, 3694 (2001).
- [9] M. Bonaldi, P. Falferi, M. Cerdonio, A. Vinante, R. Dolesi, S. Vitale, *Rev. Sci. Instrum.* 69, 3690 (1998).
- [10] A. Vinante, R. Mezzena, G.A. Prodi, P. Falferi, M. Bonaldi, M. Cerdonio and S. Vitale, *Appl. Phys. Lett.*, to be published.
- [11] C. Tesche and J. Clarke, *J. Low Temp. Phys.* 29, 301 (1977).