

100 \hbar SQUID AMPLIFIERS FOR THE ULTRACRYOGENIC GRAVITATIONAL WAVE DETECTORS

Paolo Falferi, Michele Bonaldi, Andrea Vinante,
Renato Mezzena, Giovanni Andrea Prodi,
Stefano Vitale, and Massimo Cerdonio

Istituto di Fotonica e Nanotecnologie,
CNR-ITC and INFN, Trento, Italy

Dipartimento di Fisica, Università di Padova and
INFN, Padova, Italy

Dipartimento di Fisica, Università di Trento and
INFN, Trento, Italy

Resonant Detector Sensitivity



Important Factors

- Temperature and Q of bar and transducer
- Amplifier noise
- Matching network

Effect of the Amplifier Sensitivity

$$T_n = 15 \mu\text{K} \longrightarrow \epsilon = 350 \hbar$$

$$T_n = 0.35 \mu\text{K} \longrightarrow \epsilon = 8 \hbar$$

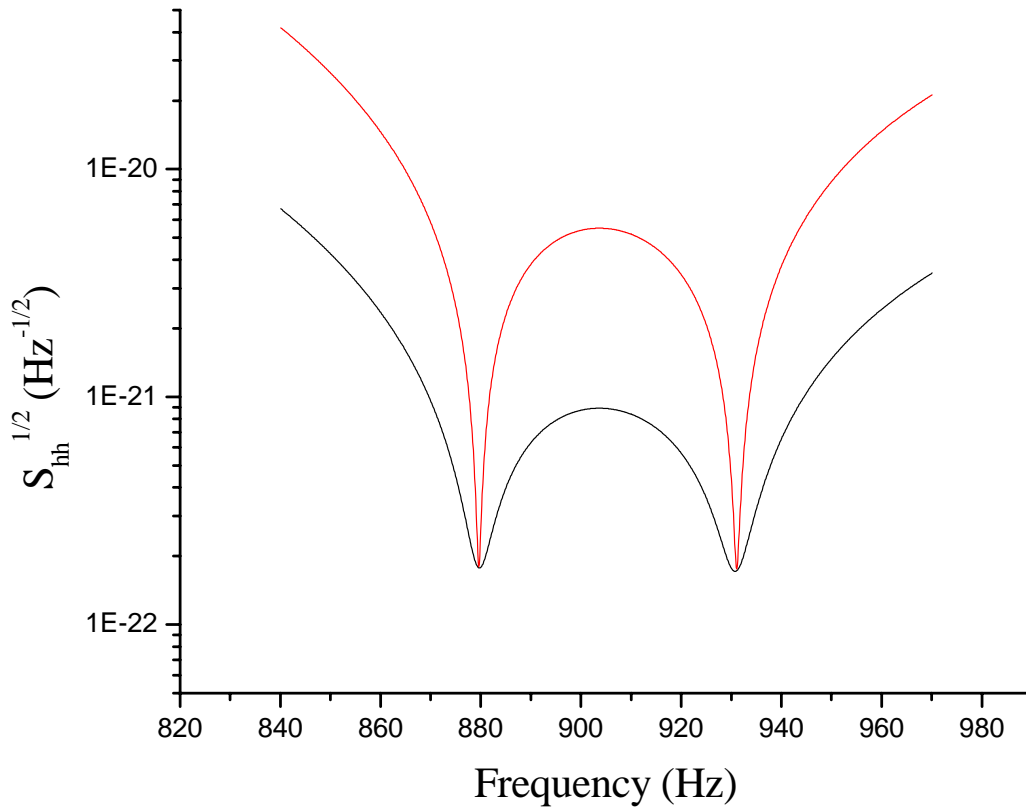

Two tuned modes (bar and transducer)

$$T_{\text{bar}} = 100 \text{ mK}$$

$$Q_+, Q_- = 3 \times 10^6$$



Low noise SQUIDs are needed

Schematic electromechanical circuit of the g. w. detector AURIGA

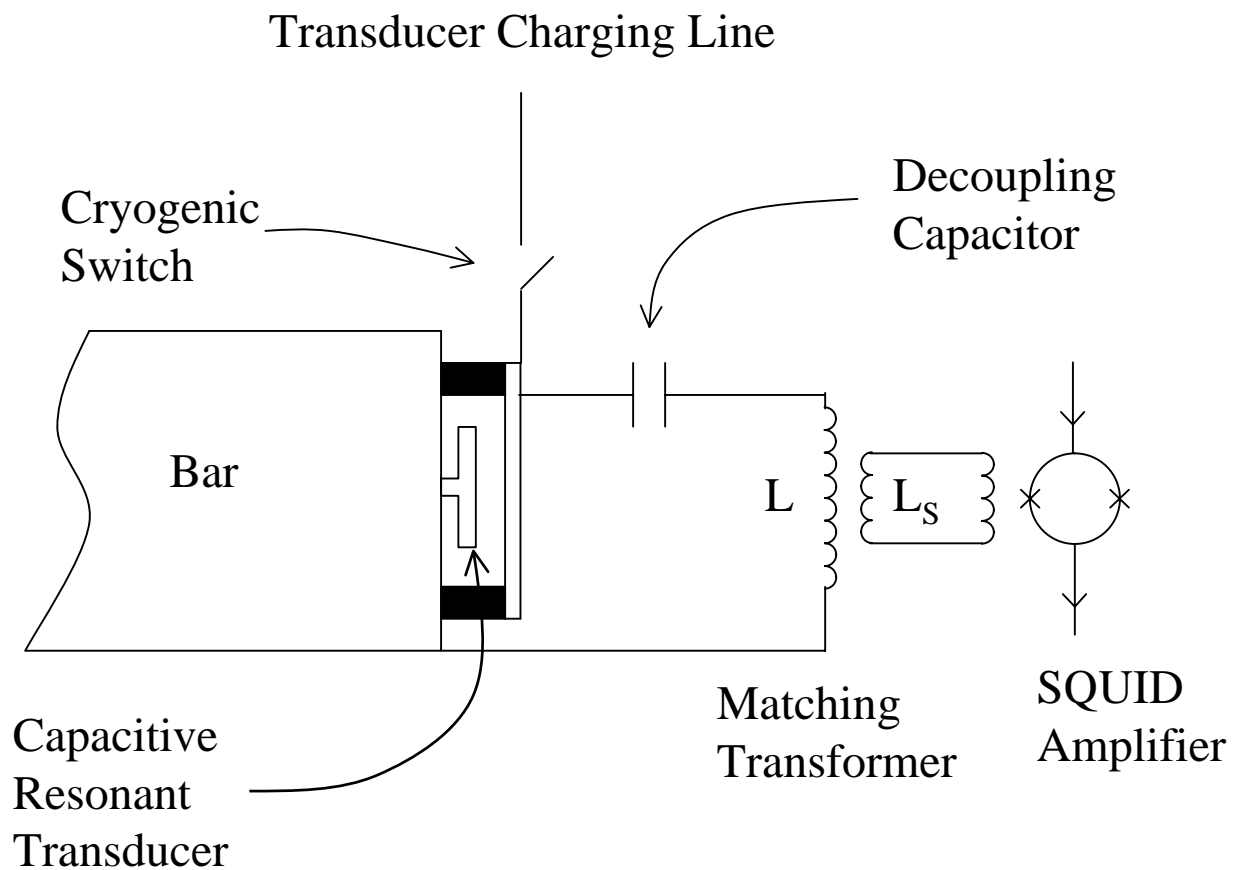

Besides bar and transducer there is a third electrical mode.

Equivalent Electrical Scheme of the AURIGA Detector

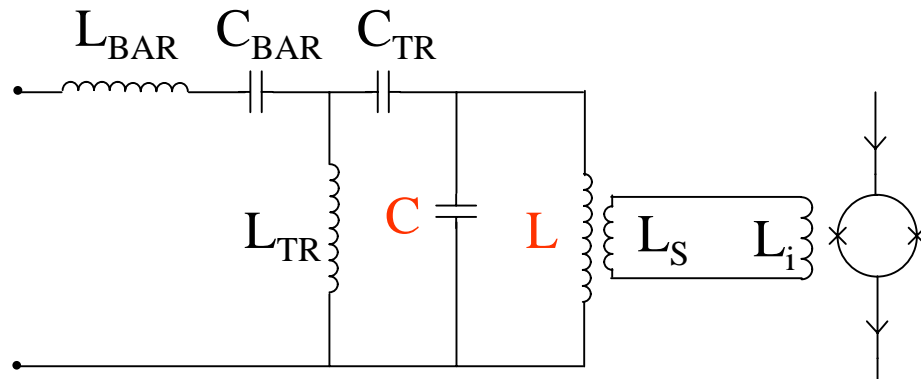

From the point of view of the SQUID the detector is constituted by 3 coupled electrical resonators

- 1) Bar
- 2) Transducer
- 3) resonator given by the transducer capacitance C and the inductance L of the matching transformer primary coil

The tuning of the third mode is convenient if

- 1) its Q is high ($\sim 10^6$)
- 2) its noise is thermal



High Q resonators with thermal noise are needed

Effect of the Tuning of the Third Mode

2 tuned modes

3 tuned modes, $Q_{el}=400000$

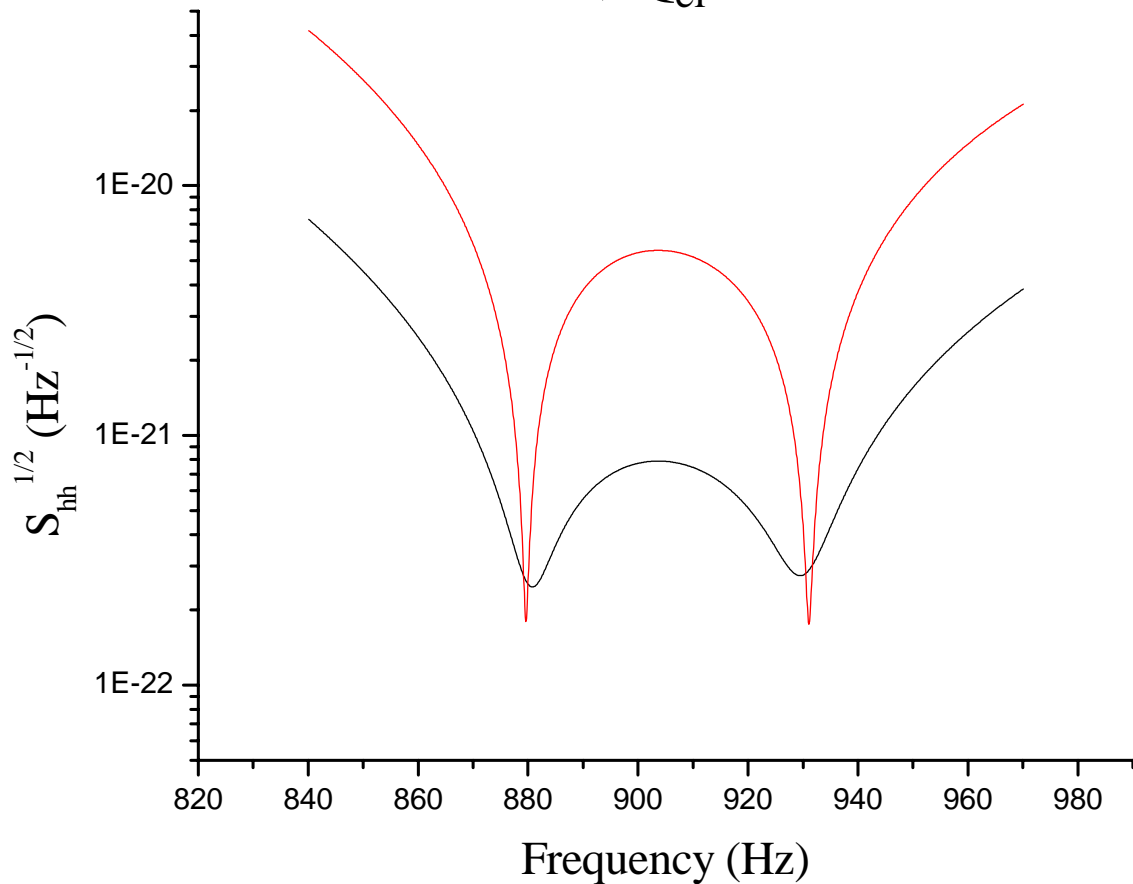

Common characteristics

- SQUID $T_n = 15 \mu\text{K}$
- $T_{\text{bar}} = 100 \text{ mK}$
- $Q_+, Q_- = 3 \times 10^6$



A full SQUID noise characterization is needed

Summary

The reasons for the development of a low noise SQUID able to operate strongly coupled to a high Q LC resonator are

- In a noise matched g.w. detector the minimum detectable energy is determined by the SQUID T_n
- The tuning of the third electrical mode is convenient only if its Q is very high
- The LC resonator is a good simulator of the detector
- With the high Q LC resonator we can give a full noise characterization of the SQUID amplifier

The SQUID Amplifier

SQUID operated in flux locked loop

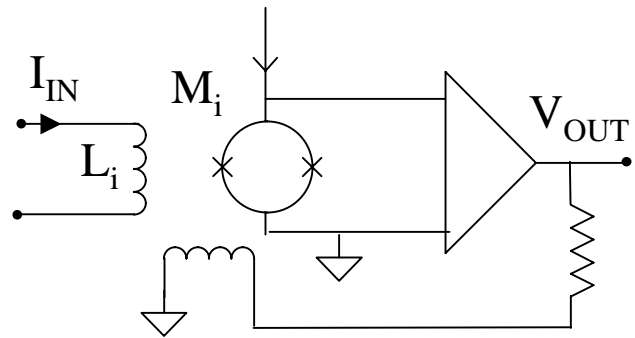

SQUID current amplifier noise model

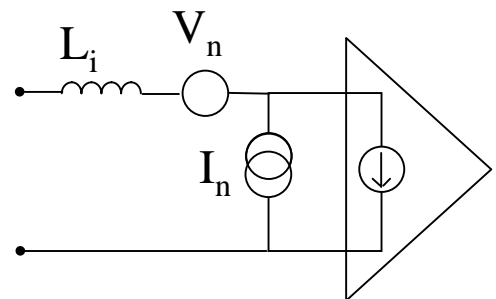

Expected noise

$$S_i \cong 16 \frac{k_B T L_{SQ}^2}{R M_i^2} \approx 10^{-25} \text{ A}^2 / \text{Hz}$$

$$S_v \cong 11 \omega^2 M_i^2 \frac{k_B T}{R} \approx 10^{-37} / \omega^2 \text{ V}^2 / \text{Hz}^3$$

$$S_{iv} \cong 12 \frac{i \omega L_{SQ} k_B T}{R}$$

Typical values

Noise Temperature

$$T_n = \sqrt{S_i S_v - \text{Im}^2 \{S_{iv}\}} / 2k_B \leq \sqrt{S_i S_v} / 2k_B$$

True Energy Resolution

$$\varepsilon = k_B T_n / \omega_0$$

Energy Resolution from additive noise
(incomplete expression)

$$\varepsilon' = \frac{1}{2} L_i S_i = \frac{L_i S_\phi}{2M_i^2}$$

Two-stage SQUID amplifier

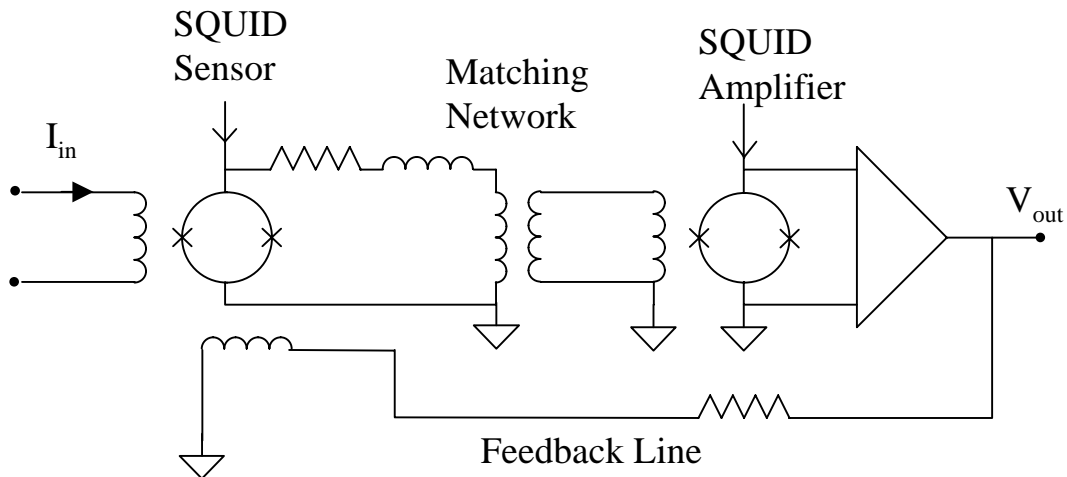

Advantages

- the noise contribution of the electronics at T_{AMB} can be made negligible
- the effect of EM interference is reduced
- the noise is, in principle, thermal

Energy Resolution from additive noise

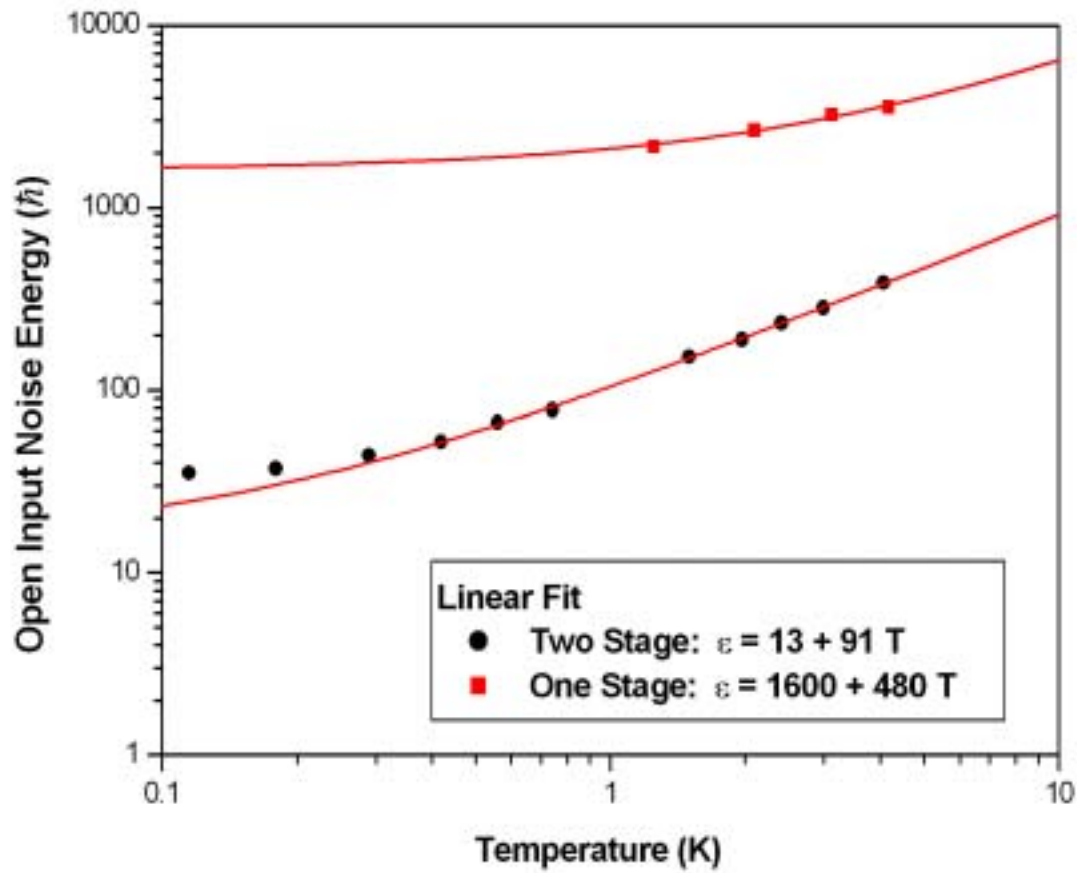

$$\varepsilon' = \frac{L_i S_i}{2} = \frac{L_i S_\Phi}{2M_i}$$

Back Action Noise Measurement

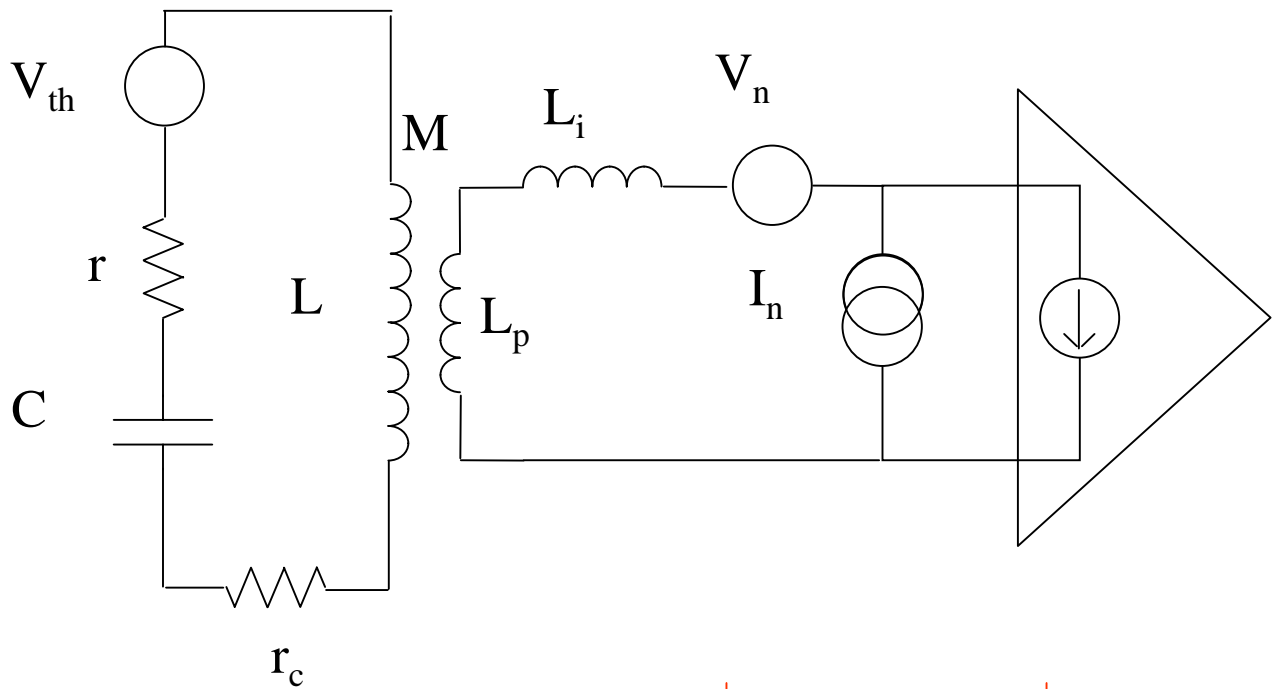

$$\sigma_{out}^2 = \left(\frac{Q_a}{Q_i} \right) (MT_R G)^2 \left[\frac{k_B T}{L_{eq}} + Q_i \frac{S_v(\omega)}{2\omega_0} \left(\frac{M}{L_t L_{eq}} \right)^2 \right]$$

Resonator thermal noise
SQUID back action noise



Characteristics of the resonators

- Resonance frequency = 200 Hz-20 kHz
- $Q = (2 - 0.5) \times 10^6$
- $L = 20 \text{ mH} - 7 \text{ H}$
- $C = 1 - 600 \text{ nF}$

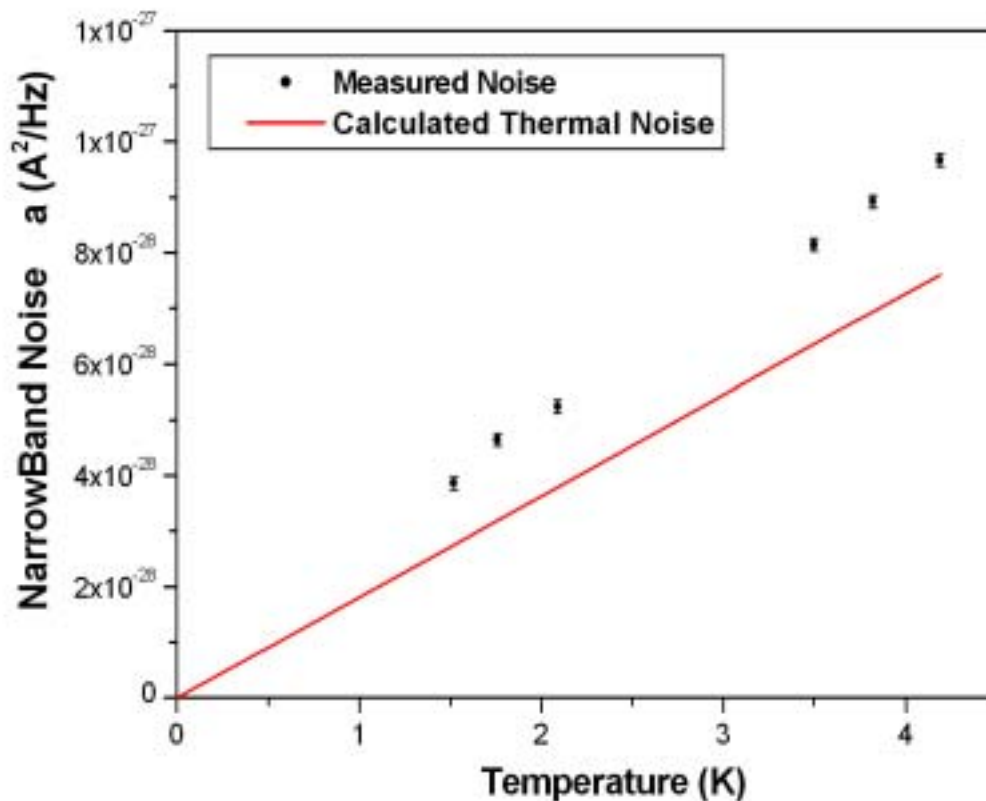

Two-stage SQUID

Resonance Frequency = 1670 Hz

Quality Factor = 1.1×10^6

$L = 0.55 \text{ H}$ $C = 19 \text{ nF}$

Two-stage SQUID Noise Temperature

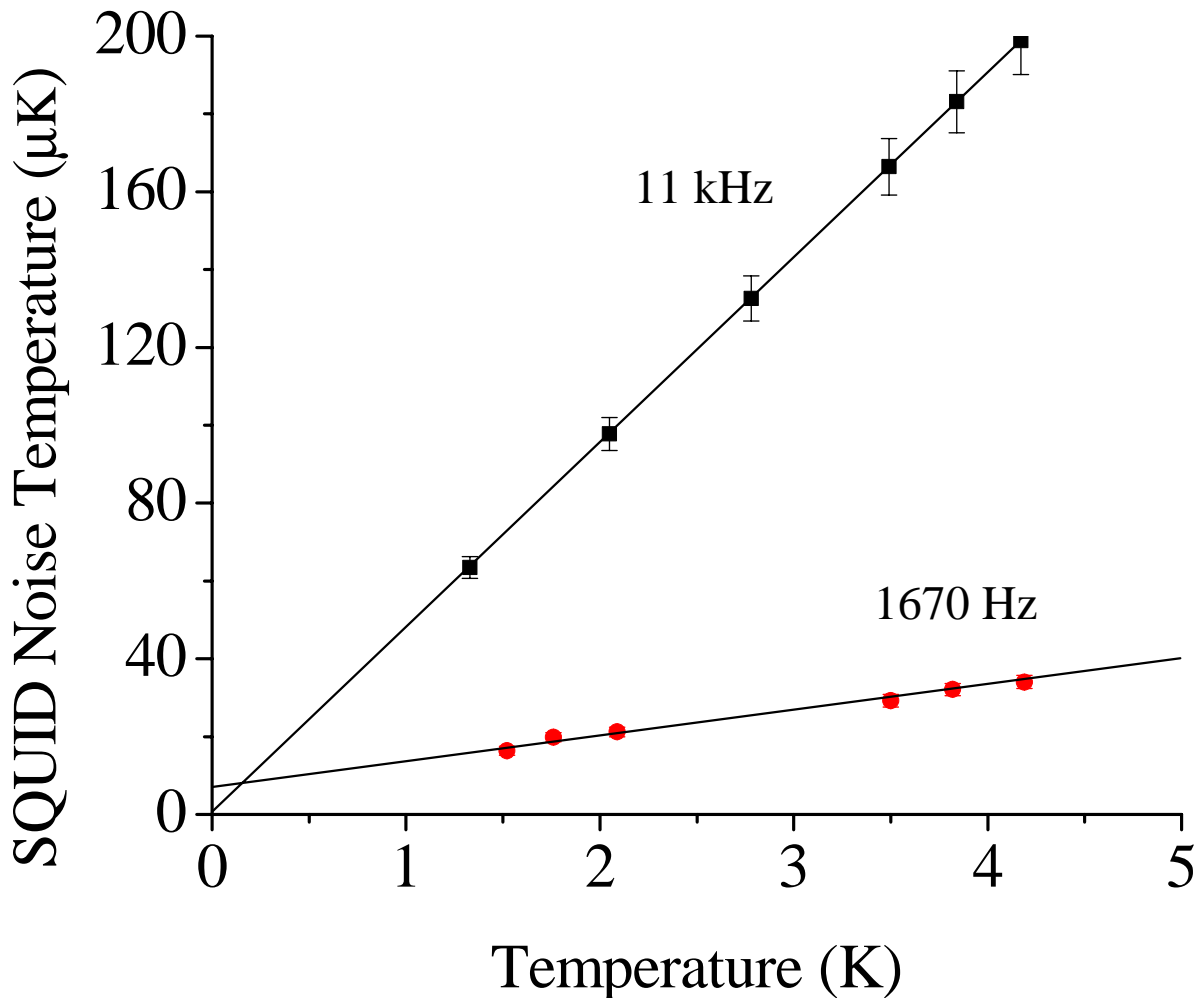

- Intercept different from zero in the $1/f$ noise region
- Slope in agreement with the theory within a factor two

TEST FACILITY at Legnaro Labs

Ultracryogenic site for the development of transduction systems

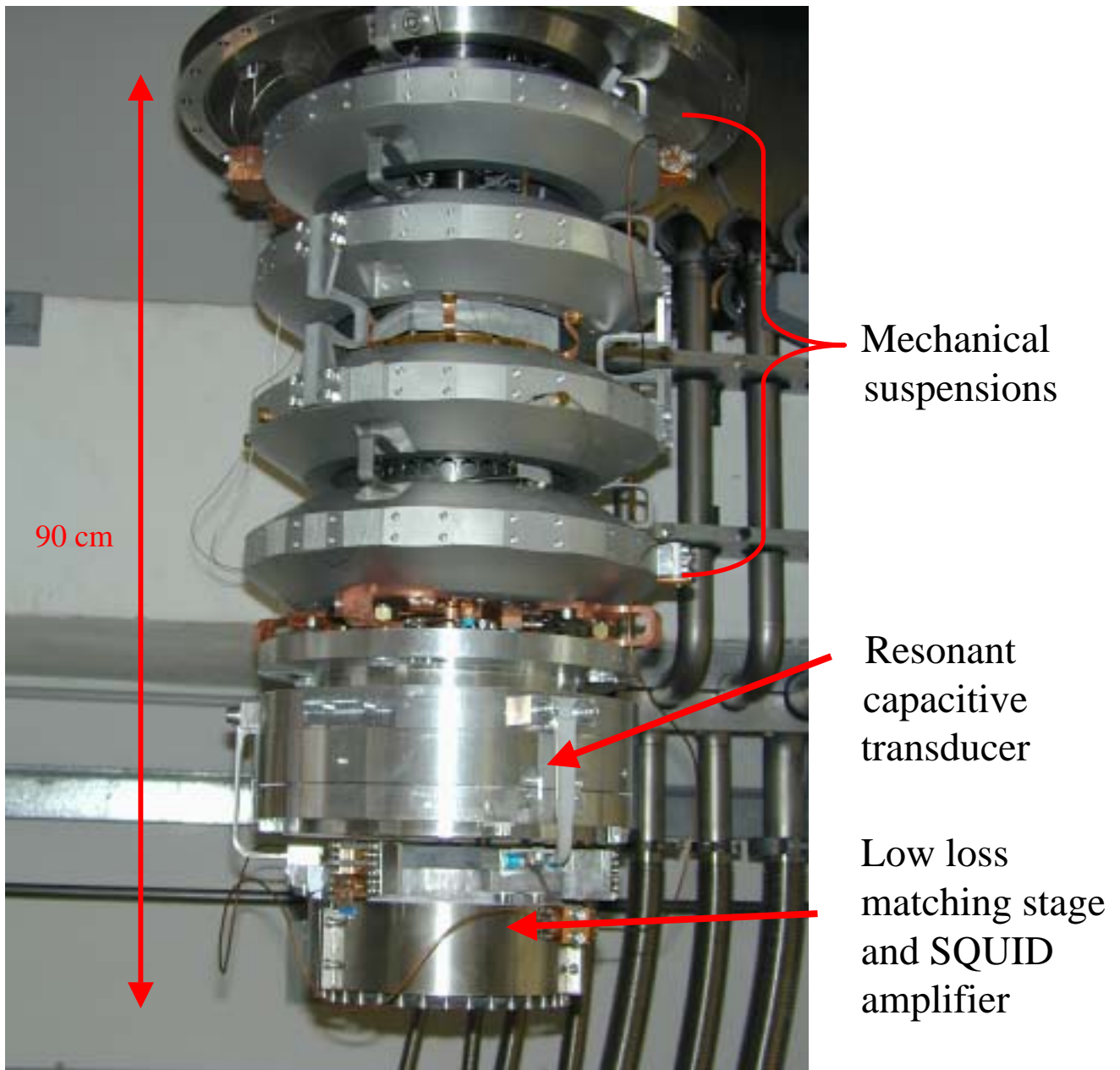

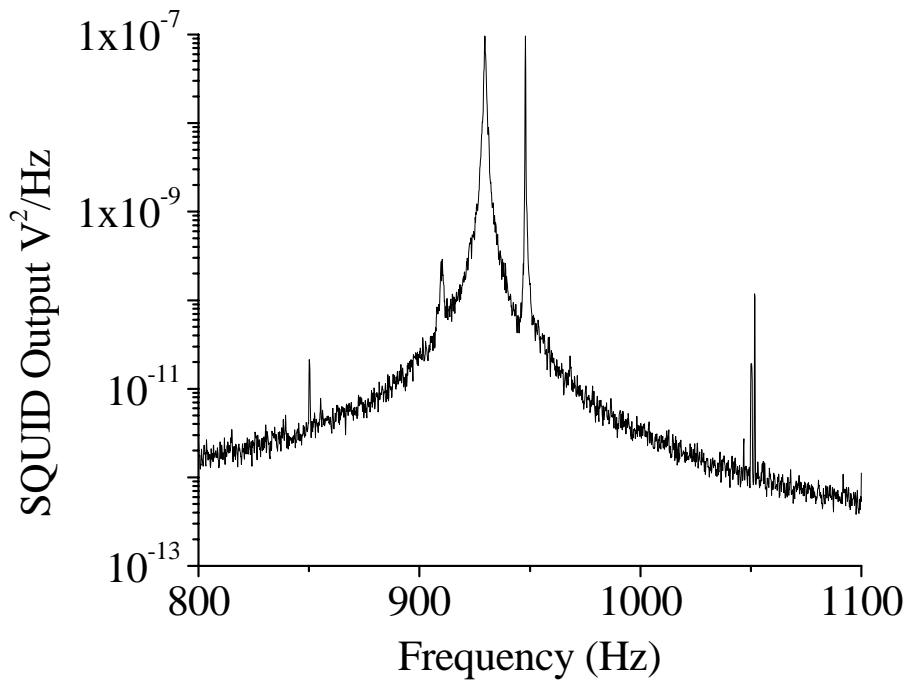

TRANSDUCER + MATCHING STAGE + SQUID

- The system is stable
- Few spurious peaks in the spectrum

TRANSDUCER

- $Q=1.1 \times 10^6$
- thermal noise at 4.2 K
- El. Field 8×10^6 V/m

ELECTRICAL MODE

- $Q=450000$
- thermal noise at 2 - 4.2 K

TWO-STAGE SQUID

- Additive and back action noise as expected
- Sufficient dynamic range