

A laser system for the AURIGA detector optical transduction chain

L. Conti^a, M. De Rosa^b and F. Marin^b

^aDipartimento di Fisica, Università di Padova, and INFN, Sezione di Padova
Via Marzolo 8, I-35131 Padova, Italy

^bDipartimento di Fisica, Università di Firenze, INFN, Sezione di Firenze, and LENS
Via Sansone 1, I-50019 Sesto Fiorentino (FI), Italy

ABSTRACT

We describe a low frequency noise laser system conceived for the readout of small mechanical vibrations. The system consists of a Nd:YAG source stabilized to a high Finesse Fabry-Perot cavity and achieves the best performance in the range 1–10 kHz, with a minimum residual noise of 4×10^{-3} Hz/ $\sqrt{\text{Hz}}$. We perform an extended characterization of the frequency stability by means of an independent optical cavity and we also measure the residual fluctuations after transmission through an optical fiber. Our apparatus is optimized for the use in an optical readout for the gravitational wave detector AURIGA, where a laser system with the characteristics here reported will allow an improvement of one order of magnitude in the detector sensibility.

Keywords: frequency stabilization, gravitational waves, optical sensor

1. INTRODUCTION

An important task for precision metrology is monitoring extremely small vibrations. The recent and still increasing progresses in opto-electronics, in particular concerning laser stabilization and high quality optical components, have boosted the possibility of using such techniques for measuring displacements. The most demanding applications concern the detection of gravitational waves (GW),¹ which is one of the most challenging tasks in nowadays Physics. The application of opto-mechanical transducers to resonant bar detectors of GW was theoretically studied by Kulagin *et al.*² J.-P. Richard and coworkers investigated in details such systems,³ performed preliminary works on suitable Fabry-Perot cavities and also tested an opto-mechanical transducer at room temperature.⁴ The basic idea is to compare the vibration of an optical cavity sensitive to the bar motion to that of a stable reference cavity, by means of resonant laser radiation.

In this work we present a laser system expressly conceived for an opto-mechanical transducer to be installed in the AURIGA ultra-cryogenic GW bar detector.⁵ The proposed apparatus is described in Ref. 6. A complete optical readout has been recently experimented on a room temperature bar identical to the one of the ultra-cryogenic detector.⁷ The required sensitivity to be competitive with the present status of AURIGA is at least 10^{-18} m/ $\sqrt{\text{Hz}}$ in a small bandwidth (about 100 Hz) around the bar fundamental resonance of about 1 kHz, where the bar detector has its peak sensitivity. This requirement implies the use of a laser system with very low frequency noise in the acoustic region, around the detection frequency. Our system presented here, while maintaining valuable characteristics concerning the frequency noise in the acoustic range, is a table-top apparatus implemented with standard equipments and can be easily reproduced for a general use in optical vibration detectors.

A critical test we have made concerns the coupling and transmission of the laser radiation through an optical fiber. This is necessary for the implementation of the AURIGA opto-mechanical readout, since the laser radiation must be delivered to the cryogenic bar. Moreover, it is very useful for any handy vibration transducer and, in general, when low-noise radiation must be conveyed to some part of the experimental apparatus. Even if we are mainly interested in the frequency noise spectral density around 1 kHz, we complete here the characterization of the system with an analysis on a broader spectral region and also estimate its time stability.

email: marin@lens.unifi.it

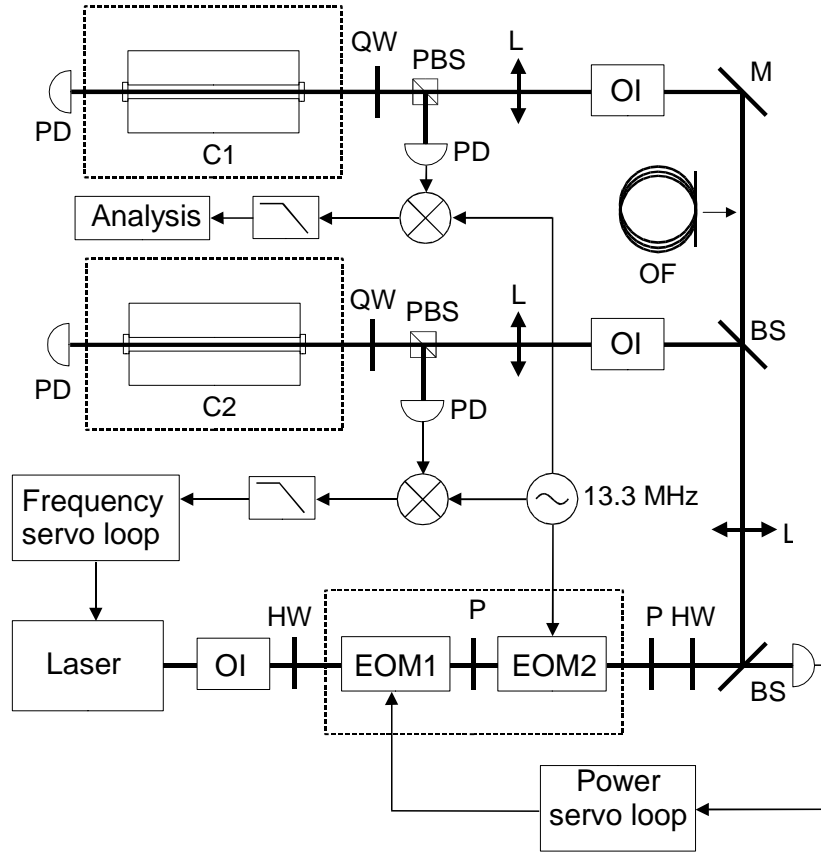

Figure 1. Experimental setup. OI: optical isolator; HW: half-wave plate; QW: quarter-wave plate; EOM#: electro-optic modulator; P: polarizer; BS: beam-splitter; PD: photodiode; C#: Fabry-Perot cavity; PBS: polarizing beam-splitter; L: lens; OF: optical fiber, which can be inserted in the path to C1. Dashed lines mark out active thermal stabilization.

2. DESCRIPTION OF THE SYSTEM

The system is composed of a phase-modulated laser source and two equal Fabry-Perot cavities: one for the laser stabilization and the other for monitoring the residual frequency fluctuations. An optical fiber can be inserted in the optical path towards one cavity. All the components are placed on the same table and the two cavities have their optical axes laying on the horizontal plane and one orthogonal to the other.

The scheme of the experimental setup is shown in Fig. 1. The light source is a commercial cw 100 mW Nd:YAG laser based on a non-planar ring geometry (Lightwave mod. 126-1064-100). Tunability is provided in two ways by the laser control box: a *slow* voltage input acts on the laser temperature with a gain of about 5 GHz/V and a time constant of a few seconds; a *fast* voltage input acts on the crystal by means of a piezoelectric actuator with a tuning coefficient of about 3.5 MHz/V and a bandwidth of about 30 kHz.

After a 40 dB optic isolator, two electro-optic modulators (EOM) are contained in a temperature stabilized aluminum box. EOM1 is used with a polarizer in an amplitude stabilization loop: a detailed description of the amplitude stabilization is reported in Ref. 8. EOM2 is a resonant modulator working at 13.3 MHz which applies a phase modulation with a depth of about 1 rad when driven by a RF power of 21 dBm. A first 50% beamsplitter selects part of the radiation which is used for the amplitude stabilization.

The laser beam is divided by a second 50% beamsplitter whose two outputs are directed towards different cavities. The optical paths include mode-matching lenses and the power impinging on each cavity is about 10 mW. For part of the measurements, the beam going to the first cavity (C1) is coupled to a single-mode,

polarization maintaining optical fiber. This fiber is composed of two 1-meter long patchcords with pigtailed collimators for input and output, and an intermediate 10-meter long fiber, connected by means of standard FC/PC components.

The coupling efficiency of the incoming radiation to the cavity TEM₀₀ mode is typically 85-90%. The alignment is very stable and it only needs slight adjustments roughly once a week. After the passage through the optical fiber, the laser beam has a better spatial quality and the coupling to the TEM₀₀ mode is $\sim 95\%$. The Fabry-Perot cavities are made by a 10 cm diameter, 20 cm long Zerodur spacer with optically contacted, fused silica mirrors. The input mirrors have higher transmission (100 ppm nominal), since the under-coupled cavity provides a better signal for the FM-sidebands technique. The actual mirror quality is limited by contamination during operation and it is different for the two cavities. The characteristics of mirrors and cavities are reported in Table 1, as deduced from the reflection and transmission signals.

Each cavity is set on a double-stage cantilever mechanical suspension machined from a single piece of Al2024. Cavity and basement are contained in a thermally stabilized, 40 cm diameter vacuum chamber. Separated vacuum systems, equipped with ion pumps, are used for the two cavities. The vacuum chamber is enclosed on a thermally insulating box. Each cavity can be heated from room temperature up to about 100°C, allowing a coarse tuning of the Fabry-Perot resonance frequency by exploiting the thermal expansion of the spacer. The temperature is then stabilized through a PID control system driven by a PC and a multifunction digital board. Fig. 2 shows the monitoring of the cavity temperature for several days of operation. The temperature stability (one standard deviation) is about 10^{-4} °C, measured on the cavity both with the in-loop thermistor and with an independent probe.

C1 can be finely tuned by a system of piezoelectric actuators (PZT) and Invar rods which compresses the Zerodur spacer. The effect of the PZT thickness variations is shared between the Invar rods and the Zerodur spacer. This mechanism allows to reduce the influence of the PZT fluctuations on the cavity length by a factor of 100 and thus minimizes the effect of the PZT thermal and electronic noise. At the same time, the Fabry-Perot resonance can be adjusted within a range of few tens of kHz by driving the PZT with low voltage electronics.

Optical circulators allow to collect and detect the laser beams reflected by the cavities. A complete characterization of the photo-detection and of the laser noise is reported in Ref. 8. The RF signal from the photodetectors, around 13.3 MHz, is demodulated in a mixer, according to the FM sidebands technique,⁹ and low-pass filtered. We obtain a Pound-Drever signal with a slope at resonance of about 10^{-3} V/Hz. The signal from C1 is simply amplified and low-pass filtered. The Pound-Drever signal from the second cavity (C2) is used as error signal in a feedback loop for locking the laser. The overall servo loop has a 0 dB frequency of 30 kHz and a gain of 120 dB at 1 kHz. Details on the loop electronics can be found in Ref. 10.

3. RESULTS AND DISCUSSION

In Fig. 3 we report the frequency noise spectra of the free-running laser (a) and of the laser locked to C2 (b).¹¹ Both spectra are referred to the same cavity C2 that is used for stabilizing the laser. We also report in the figure the noise spectrum measured after the mixer with the laser far from resonance (trace c). This is given by the sum of electronic noise and laser amplitude noise and it represents a lower limit for the residual frequency

Table 1. Parameters of the two cavities.

Cavity	C1		C2	
Length (m)	0.2		0.2	
FSR (MHz)	750		750	
Finesse	17000		36000	
Input power (mW)	10		7	
Mirror	in	out	in	out
Radius of curvature (m)	1	1	∞	1

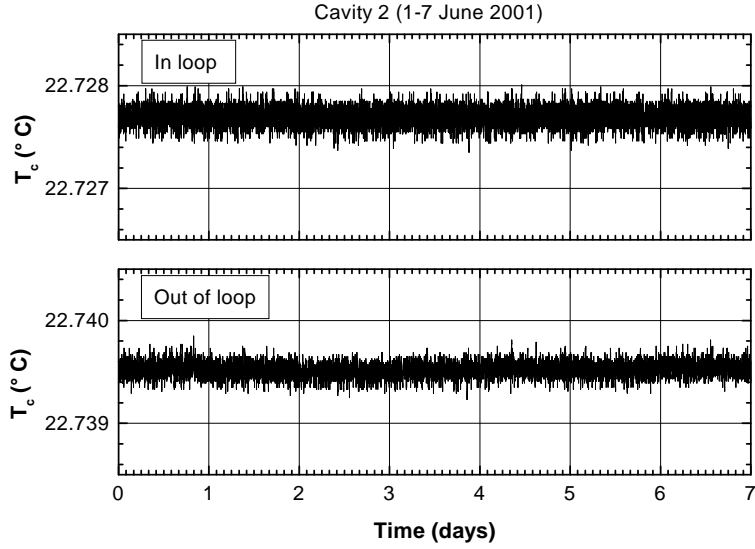

Figure 2. Residual temperature fluctuations of a stabilized Zerodur cavity. Upper curve: from the probe used in the servo-loop. Lower curve: from an independent probe. The difference in the average values is within the calibration accuracy.

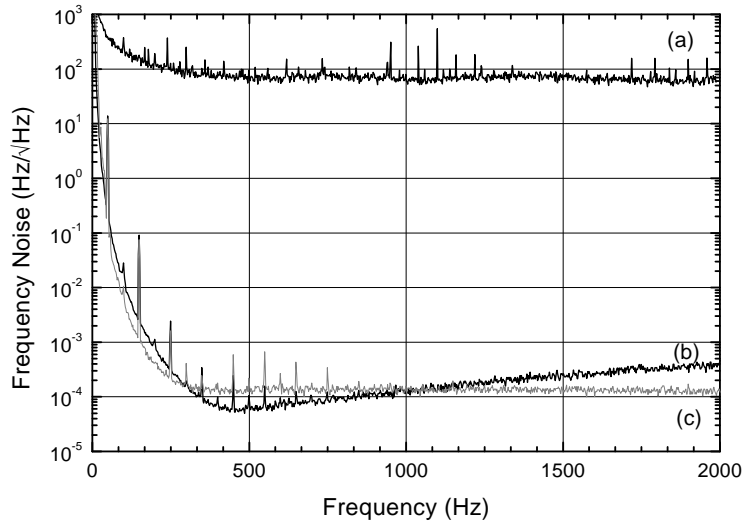

Figure 3. (a) Frequency noise spectral density of the free-running laser. (b) Noise spectrum of the in-loop signal for the laser locked to C2. (c) Noise measured with the laser far from resonance. Frequency resolution: 2 Hz.

noise of the laser when locked to the cavity. The signal in trace (c), around 1 kHz, is just ~ 3 dB above the laser shot noise, that gives the lower limit attainable in classical experiments. The in-loop signal (b) is below trace (c) in the range 100 Hz–1 kHz, demonstrating that the feedback loop provides the necessary gain in the frequency region of interest.

In order to obtain a reliable estimation of the residual laser frequency fluctuations, we use the signal from C1 as discriminator. The laser light, frequency locked to C2, and C1 are brought into resonance by tuning the temperature of the cavities and the PZT of C1. The laser can be maintained locked to C2 and resonant with

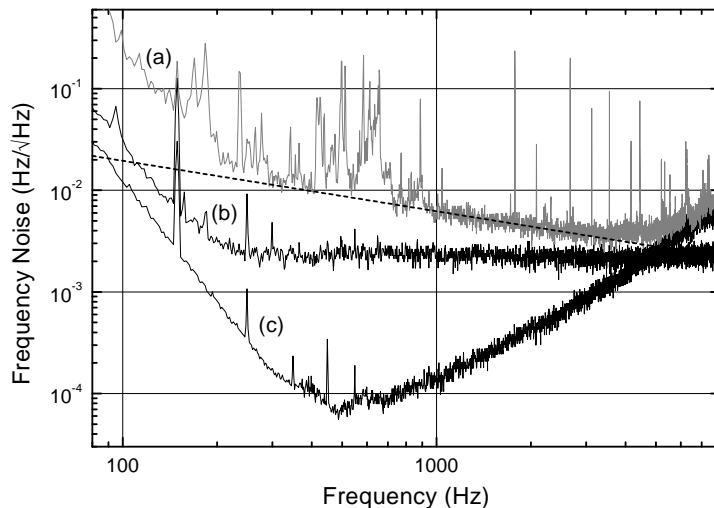

Figure 4. (a) Residual frequency noise of the laser when locked to C2, measured with respect to C1. (b) Noise spectrum measured on the C1 detector when the laser is far from resonance. (c) In-loop spectrum. Frequency resolution: 2 Hz. The dashed line shows the trend of a $1/f$ power noise.

C1 for long periods (several hours) by applying a slow correction to the PZT voltage, using the Pound–Drever signal from C1 as error signal. In this way, we obtain a noise spectrum which is reported in Fig. 4 (trace a). If we assume that the fluctuations in the length of the two cavities are not correlated, the signal in trace (a) represents an upper limit to the laser frequency noise. The frequency fluctuations of the locked laser with respect to the second cavity are originated, at least, by the sum of three independent contributions corresponding to the two far-from-resonance signals (for the two cavities) and to the in-loop signal (trace (c) in Fig. 4). The measured laser frequency noise is about 9 dB higher than this limit around 1 kHz, due to excess $\sim 1/f$ noise whose origin is presently under investigation. The minimum spectral density is about $4 \times 10^{-3} \text{ Hz}/\sqrt{\text{Hz}}$, measured around 4 kHz. Above this frequency the spectrum increases again, due to the low servo-loop gain.

An important task for this work is to verify whether the passage through the single-mode fiber deteriorates the spectral purity of the locked laser. The noise spectrum for this configuration is reported in Fig. 5, together with the expected noise calculated from the far-from-resonance and in-loop spectra. If we consider the 20% accuracy in the spectra calibration, we cannot appreciate any difference in the frequency noise spectrum between the in-fiber and the in-air propagation, except for a different distribution of some narrow peaks which are due to acoustic disturbances. The most relevant structure in the noise spectrum is a strong peak at 57 Hz which is due to a mechanical resonance of the optical table, as we have verified with the help of accelerometers.

Even if it is not relevant to the purposes of the AURIGA opto-mechanical transducer, we have completed the system characterization with a wide-band analysis. Above 4 kHz, the laser frequency noise is determined by the limited loop gain. More interesting is the long-term stability, measured by means of the PC board. For the following measurements we have applied no feedback to the PZT and the data acquisition took place just while the laser was resonant with C1 thanks to the cavities passive stability. A time-series $x(t)$ of the relative frequency is acquired and the data analysis in this case includes the evaluation of the low-frequency noise spectrum and of the Allan variance.¹²

The data reported in Fig. 6 correspond to two different experimental situations, namely with (open circles) and without (closed circles) an offset voltage applied to the PZT. The 57 Hz peak, and a few others at lower frequency, determine the Allan deviation $\sigma_A(\tau)$ below 10 s. Above 0.1 s, when a voltage is applied to the PZT, the frequency stability is deteriorated by fluctuations in the applied voltage, in spite of the mechanical reduction system described above. No such effect is observable in the noise spectra: the excess fluctuations are limited

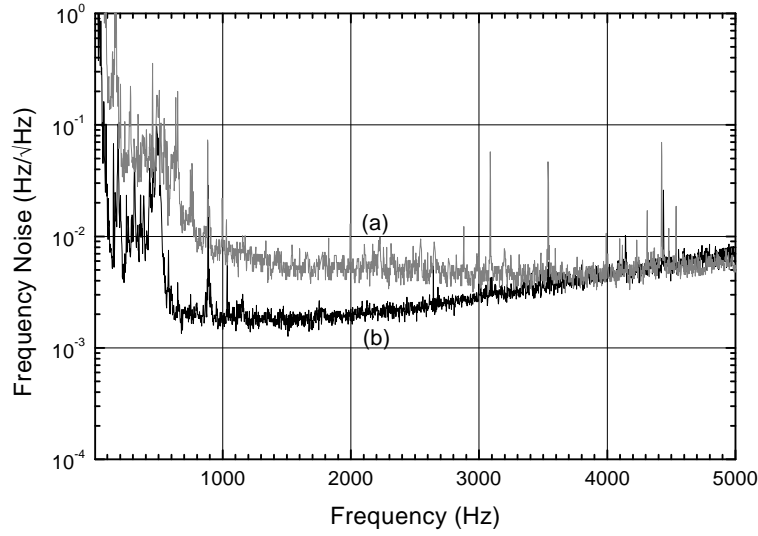

Figure 5. (a) Frequency noise of the laser after the passage through the single-mode optical fiber. (b) Lower limit to the frequency fluctuations (see text). Frequency resolution: 2 Hz.

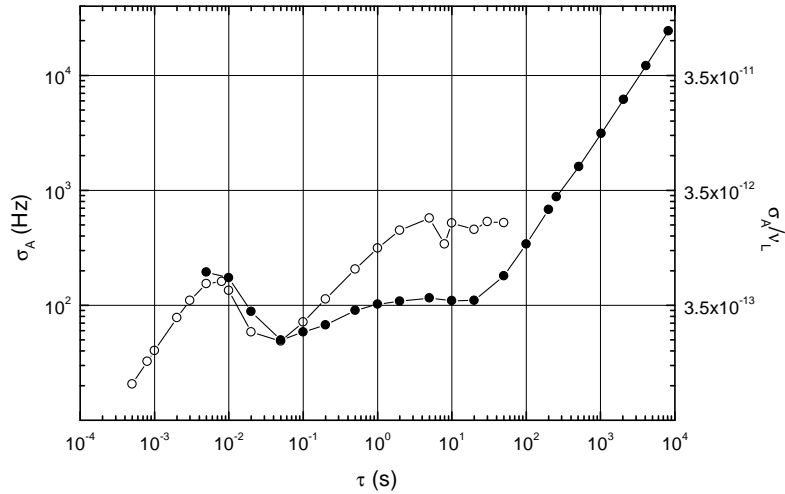

Figure 6. Allan deviation of the stabilized laser. Closed circles: with no voltage applied to the PZT. Open circles: with offset voltage applied. The scale on the right gives the relative Allan deviation: σ_A/ν_L , where $\nu_L = 2.82 \times 10^{14}$ Hz is the laser frequency.

to the long term range. Above 100 s, the Allan deviation increases as $\sigma_A(\tau) = 3\tau$. This trend is due to a drift which affects the length of the cavities, corresponding to about 3 Hz/s in the difference between the resonance frequencies, observed over a period of several weeks. During these measurements the cavities are kept at 40°C and 23°C respectively and the corresponding measured thermal expansion coefficients are $2 \times 10^{-8} \text{C}^{-1}$ and $4 \times 10^{-8} \text{C}^{-1}$. The temperature stability of 10^{-4}C should guarantee frequency fluctuations below 2 kHz, i.e., in a period of one week we should not observe drifts larger than 4×10^{-3} Hz/s. The observed drift is well above this limit and is probably due to long-term relaxations of the Zerodur.

4. CONCLUSIONS

We have presented a frequency stabilized laser system to be used in high sensitivity interferometers. Our system represents a trade-off between high performances and ease of implementation. Indeed, it does not involve cryogenic cavities, nor huge and sophisticated mechanical isolation systems and it is probably the most stable laser source obtained in a table-top experiment. As a further, important feature the laser is coupled to a single-mode optical fiber, which is a fundamental characteristics for most applications. In our knowledge, this is the first characterization of the frequency noise characteristics of a fiber-coupled laser system.

Our system is particularly conceived for the optical readout to be used in the AURIGA ultra-cryogenic GW detector. For this reason, it is focused on the frequency stability around 1 kHz. In particular, the stabilized laser exhibits a frequency noise below 10^{-2} Hz/ $\sqrt{\text{Hz}}$ between 1 kHz and 10 kHz. A broader range characterization shows a noise spectral density still below 10^{-1} Hz/ $\sqrt{\text{Hz}}$ for frequencies above 100 Hz, except for some narrow resonances, and a best relative Allan deviation of 2×10^{-13} around 10^{-1} s and 10^{-3} s.

A standard implementation of this laser system in a sensitive displacement measurement or in an accelerometer implies the use of a sensing Fabry–Perot cavity. This cavity should be designed without any tuning option, in order to limit the noise, and its Free-Spectral-Range is thus limited by the tuning range of the laser. For a Nd:YAG source, the typical tuning range is about 30 GHz and the sensing cavity cannot be shorter than 5 mm. Our laser system thus allows a sensitivity of about 10^{-19} m/ $\sqrt{\text{Hz}}$ between 1 kHz and 10 kHz. In particular, if we consider the opto-mechanical transducer described in Refs. 6,7 and the parameters of the AURIGA cryogenic detector, the frequency noise of 6×10^{-3} Hz/ $\sqrt{\text{Hz}}$ around 1 kHz allows a minimum detectable GW pulse of $h_{\min} = 4 \times 10^{-20}$ with a useful -6 dB bandwidth of about 50 Hz. These figures represent a significant improvement with respect to the present status,¹³ characterized by a sensitivity $h_{\min} = 4 \times 10^{-19}$ and a bandwidth of about 2 Hz. The results here reported are particularly important since AURIGA already reached the best sensitivity among the operating GW detectors and optical readout systems can be very useful for advanced GW massive detectors.

REFERENCES

1. For a comprehensive review of the most recent results of GW research see the special issue of *Class. Quant. Grav.* **19**, 1227–2049 (2002).
2. V.V. Kulagin, A.G. Polnarev, and V.N. Rudenko, “A combined optical-acoustical gravitational antenna”, *Sov. Phys. JETP* **64**, 915–921 (1986).
3. J.-P. Richard, “Laser instrumentation for one-phonon sensitivity and wide bandwidth with multimode gravitational radiation detectors”, *J. Appl. Phys.* **64**, 2202–2205 (1988). J.-P. Richard, “Approaching the quantum limit with optically instrumented multimode gravitational-wave bar detectors”, *Phys. Rev. D* **46**, 2309–2317 (1992).
4. Y. Pang and J.-P. Richard, “Room-temperature tests of an optical transducer for resonant gravitational wave detectors” *Appl. Opt.* **34**, 4982–4988 (1995).
5. G.A. Prodi, L. Conti, R. Mezzena, S. Vitale, L. Taffarello, J.P. Zendri, L. Baggio, M. Cerdonio, A. Colombo, V. Crivelli Visconti, R. Macchietto, P. Falferi, M. Bonaldi, A. Ortolan, G. Vedovato, E. Cavallini and P.L. Fortini “Initial operation of the gravitational wave detector AURIGA” in *Gravitational Waves. Proceedings of the second Edoardo Amaldi Conference*, edited by E. Coccia *et al.* World Scientific, Singapore, 1999, pp. 148–158. For more information, see also <http://www.auriga.lnl.infn.it>.
6. L. Conti, M. Cerdonio, L. Taffarello, J. P. Zendri, A. Ortolan, C. Rizzo, G. Ruoso, G. A. Prodi, S. Vitale, G. Cantatore, and E. Zavattini, “Optical transduction chain for gravitational wave bar detectors” *Rev. Sci. Instrum.* **69**, 554–558 (1998).
7. M. De Rosa, L. Baggio, M. Cerdonio, L. Conti, G. Galet, F. Marin, A. Ortolan, G. A. Prodi, L. Taffarello, G. Vedovato, S. Vitale, and J. P. Zendri, “First room temperature operation of the AURIGA optical readout”, *Class. Quant. Grav.* **19**, 1919–1924 (2002).
8. L. Conti, M. De Rosa and F. Marin, “Low-amplitude-noise laser for AURIGA detector optical readout”, *Appl. Opt.* **39**, 5732–5738 (2000).

9. R. W. P. Drever, J. L. Hall, F. Kowalski, J. Hough, G. M. Ford, A. J. Mulney, and H. Ward, “Laser phase frequency stabilization using an optical resonator”, *Appl. Phys. B* **31**, 97–102 (1983).
10. L. Conti, “An optical readout for the AURIGA resonant gravitational wave detector”, PhD Thesis, University of Trento, (1999). Downloadable at the AURIGA web site: <http://www.auriga.lnl.infn.it/publications/publications.html>.
11. All the spectra reported in this work are one-sided, i.e., reported to positive frequencies.
12. D. W. Allan, “Statistics of atomic frequency standards”, *Proceedings of the IEEE* **54**, 221–231 (1966).
13. J.P. Zendri, L. Baggio, M. Bignotto, M. Bonaldi, M. Cerdonio, L. Conti, M. De Rosa, P. Falferi, P.L. Fortini, M. Inguscio, A. Marin, F. Marin, R. Mezzena, A. Ortolan, G.A. Prodi, E. Rocco, F. Salemi, G. Soranzo, L. Taffarello, G. Vedovato, A. Vinante, and S. Vitale, “Status report and near future prospects for the gravitational wave detector AURIGA”, *Class. Quant. Grav.* **19**, 1925–1930 (2002).

L. Conti, R. Mezzena, S. Vitale, L. Taffarello, J.P. Zendri, L. Baggio, M. Cerdonio, A. Colombo, V. Crivelli Visconti, R. Macchietto, P. Falferi, M. Bonaldi, A. Ortolan, G. Vedovato, E. Cavallini and P.L. Fortini