

STATUS OF THE CAVIAR DETECTOR AT LISE-GANIL

L. Perrot[#], IPNO-IN2P3-CNRS, Orsay, France
S. Grévy, C. Houarner, R.Hue, C. Marry, GANIL, Caen, France
S. M. Lukyanov, Yu. Penionzhkevich, FLNR JINR, Dubna, Russia

Abstract

Physics that motivated the building of the LISE magnetic spectrometer, main ideas exposed in the scientific council of GANIL June 4th 1981 by M. Brian and M. Fleury, were: atomic physics studies with stripped ions and the study of new isotopes produced by the fragmentation of beams. The LISE line is a doubly achromatic spectrometer (angle and position), with a resolution better than 10^{-3} . Since the first experiment done in 1984, several improvements of the spectrometer were performed: use of an achromatic degrader (1987, used for the first time in the world), building of the achromatic deviation and the Wien Filter (1990), building of a new selection dipole and associated vertical platform (1994), building of the new LISE2000 line (2001), use of the CAVIAR detector (2002), building of the CLIM target (2007). Despite an extreme international competition, the LISE spectrometer remains a world-leader equipment using more than 50 % and up to 90 % of the beam time available at GANIL. This paper presents the status of CAVIAR detector which consists of a MWPC dedicated to in flight particle position at the first dispersive plane of LISE. Since two years, intensive efforts were done with the objective to make available a “plug and play” detector for nuclear physic experiment. We will describe the system from MWPC up to acquisition system. As example few experimental results will be presented.

INTRODUCTION

In the energy domain of GANIL (from 30 up to 100 MeV/u), a large fraction of the reaction cross section goes into the fragmentation of the projectile. Fragments are emitted around 0° at velocities very close to the one of the incident beam, in a mass range which spreads from the projectile. A physics program with the goals to study exotic nuclei and secondary radioactive beams started in the early eighties [1]. LISE provides two main selection criteria in the identification process of reaction products. The first one is the magnetic rigidity ($B\rho=Av/Q$) given by the first analyzing dipole D31. Dispersion term of the section is typically 16.5mm/% of $\delta p/p$. Slits are placed at the dispersive plane with full aperture of ± 45 mm. The momentum acceptance is equal to $\Delta p/p=2.72\%$. The second selection is the differential energy loss (dE) of the ions in materials, by means of an achromatic degrader located in the intermediate focal plan of the spectrometer (cf. Fig. 1). The combination of $B\rho$ and dE measurements provides a selection to A^3/Z^2 (with B the magnetic field, ρ the radius, A the mass number, v the velocity and Z the atomic number). Beam line acceptance is around 1msr. These two previous selections are the selection reference of LISE spectrometer.

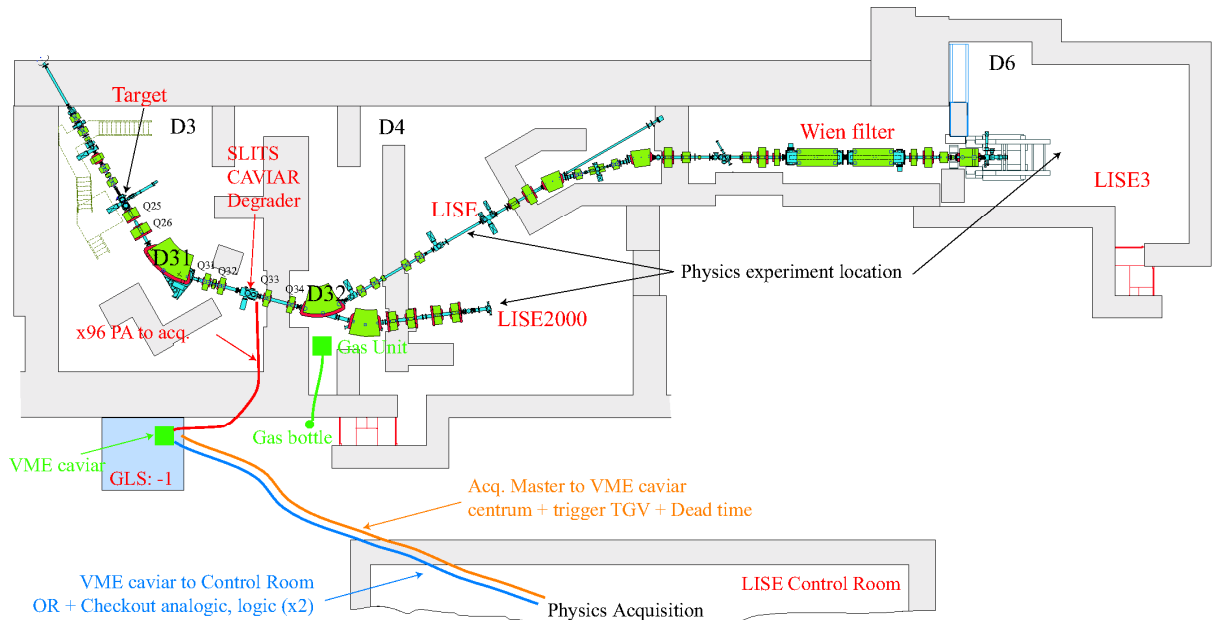

Figure 1: View of the LISE spectrometer. Essential beam lines elements can be located. CAVIAR and physics acquisition location are precise.

[#]perrot@ipno.in2p3.fr

The angle of entry of the primary beam with respect to the axis of the spectrometer has been made variable (from 0° up to 3.5°). This improvement allows the suppression of remaining incompletely stripped beam charge states in experiments with heavy beams ($Z > 30$).

A third selection was added in the early nineties for increasing the rejection power. In order to filter out a given velocity, it has been constructed a device in which an electrostatic and a magnetic field are crossed in a "classical" Wien filter [2]. The flight path between the target and the final focus is around 43m. The line was named LISE3.

In 2001, the new line LISE2002 was built for increasing magnetic rigidity (until 4.2Tm) and beam line acceptance [3]. LISE2002 line is connected to old LISE line after the intermediate focal plane. It imposed quadruples and first dipole changing.

More recently, according the various LISE features, a new rotating target was build. This target can accept beam power until to 2kW [4].

During an experiment carried out in 2002, a multi-wires proportional detector was placed in the dispersive plane of the spectrometer [5]. This detector named CAVIAR by the GANIL staff allowed the measuring of the magnetic rigidity of each fragment via its position in the focal plane, improving the mass-to-charge A/Q resolution.

Activities on this detector began again in 2006 with α -source and beam test before a real experiment. During the two last years, various improvements have been done. We will present in this paper the status of the detector. We will first describe the detector. Next, we will give the methodology for tune the system. Finally, few results will be presented.

CAVIAR DETECTOR

To take the maximum benefit of the secondary beam intensity produced in the target, momentum selection slits of the LISE dispersive plane must be opened. Counting rate expected can be increasing by a factor 5. But the major difficulty is that heavy nuclides have too closed mass-to-charge A/Q ratio and time of flight (which is the case for fragmentation beams). For the full slits aperture, nuclides can not be distinguished. Contaminants rates can largely dominate the very low production rates of the interesting nuclide.

Identification can be providing using a MWPC [6] placed at the dispersive focal point (cf. Fig. 1). Each wire detects the horizontal position of the particle at this point. With a coincidence between CAVIAR and detectors placed at the final focal plane (LISE2000 or LISE3) and a time of flight measurement, we can reconstruct precisely the mass-to-charge ratio event by event. Maximum counting rate per wire is 10 kHz.

FLNR JINR team performs MPWC and preamplifiers R&D according their great experience [7-8].

CAVIAR is a powerful tool for research and nuclear spectroscopy on nuclides produced with very low cross section. For example, it will concern nuclides closed the proton or the neutron drip-line. In addition, CAVIAR

detector can be used during LISE tuning at the beginning of experiment. We obtain nuclides momentum distribution in the first LISE dispersive plane and optimize properly the spectrometer to the nuclide of interest.

Mechanics

The sensitive area of this detector is 96mm in the horizontal plane and 32mm in the vertical plane. These sizes are defined by the secondary beam sizes and maximum aperture of the slits in the dispersive plane. CAVIAR is composed by 96 wires of $10\mu\text{m}$ in diameter with 1mm step between each of them. Wires are gilded Tungsten. Two $1.5\mu\text{m}$ thicknesses Aluminum Cathodes foils are placed 3.4mm distance from anode (cf. Fig. 2).

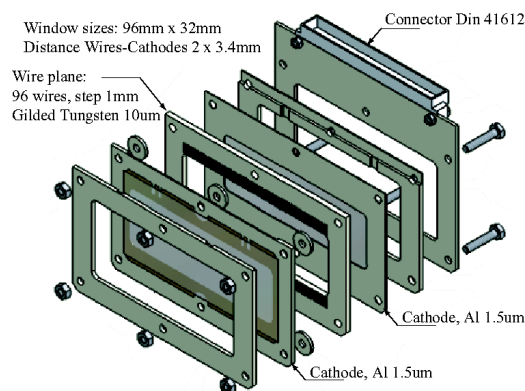

Figure 2: Mechanical view of the sensitive area of CAVIAR.

Detector is filling with variable and less than 50mbar Isobutene (C_4H_{10}). Two Kapton ($\text{C}_{22}\text{H}_{10}\text{N}_2\text{O}_5$) windows of $8\mu\text{m}$ thicknesses are used. They isolate the detector from beam line vacuum [9]. CAVIAR is a low interceptive detector for high energy beams.

CAVIAR detector can be easily inserted in the beam line using a classical gage, which has connections on the top for high voltage, gas circulation and 96 out signals from wires. On the beam axis, CAVIAR is locating 45mm after the selection slits.

Gas System

The Isobutene was choosing for his cost and good properties to nuclides and energy range. For safety reason, gas filling system is located outside the experimental room (cf. Fig. 1). This gas unit, developed at GANIL, is inside the experimental room. We can control it by software. The gas unit system is working in a way to protect the detector in case of any trouble. Without gas regulation, valve is open to obtain the same vacuum in the detector and in the beam vacuum chamber.

Signal Pre-amplification

Directly fixed to the propeller, 6 boxes of 16 channels of pre-amplification are connected. Each wire is individually read out. Using this type of charges preamplifiers and due to ECM compatibility, we need

short lengths from wires up to PA entry. Figure 3 shows signals amplitudes after amplification.

New tension preamplifiers have been recently built at JINR for take into account to eventual long distance between detector and preamplifiers. Tests with beam have been done in March 2009.

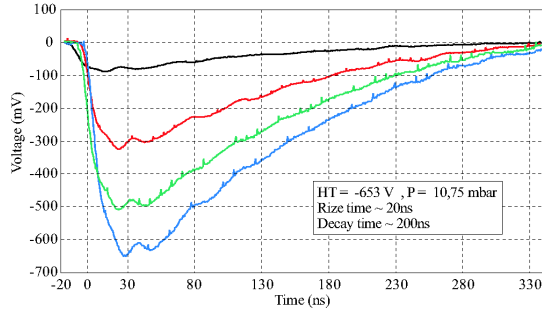

Figure 3: Amplificated signals (50Ω adapt.).

CAVIAR Acquisition System

The 96 amplified signals are transport along 16 m cables until the acquisition system. Analog signals process is based on VME standard [10]. 6 DDM16 modules develop at GANIL are inserted [11]. Each DDM16 manage 16 channels. The module provides leading edge triggering, delay time and memorization. Scalers, tests, checkouts of analogical and logical signals are also available.

When a particle passes truth CAVIAR detector, a signal can be induced on a wire. Signal is treated by associated DDM16 channel. The particle can be also detected by the detection system placed at the final focus point which is the master. The associated trigger generated by a validated event in the final detection system is transport until a TGV (Trigger Général VME) module with a CENTRUM receptor, which can correlate to the event number with the logical signal generated by the DDM16 (cf. Fig. 4).

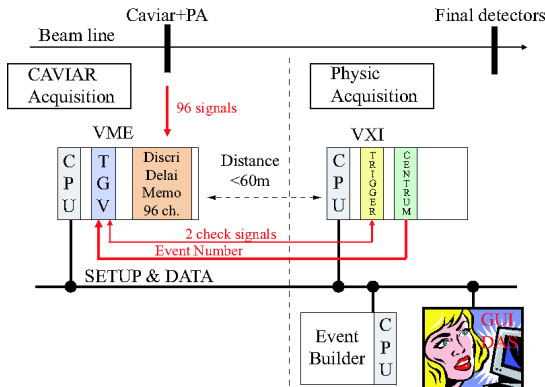

Figure 4: Synoptic adopted for CAVIAR.

Due to beam line flight path, cables lengths and various signals treatments, all CAVIAR logical signals must be delayed to obtain the good memorization (cf. Fig. 5).

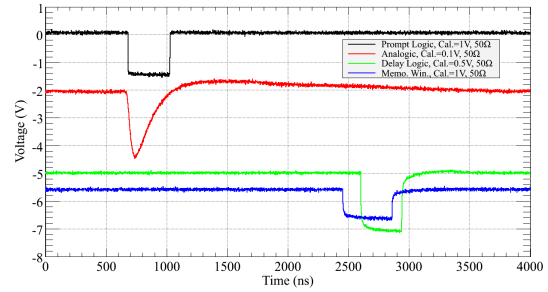

Figure 5: Synoptic adopted for CAVIAR.

CAVIAR memorization pattern is defining in 6 words of 16 bits.

Finally, each DDM16 provide a “Or” of its 16 channels. The 6 resulting Or can be mixed for produced a single one. This “Or” logic can be use for the time measurement during the experiment.

CAVIAR TUNING

We will briefly describe up to now the method for tune the CAVIAR detector.

First of all, detector must be connected to the line few days before the experiment. Vacuum in both chamber and detector must be in agreement with normal condition (around 10^{-6} mbar). Some test must be done with gas circulation for ensure that no gas leak occurs with the Kapton windows. At the experiment start, gas pressure must be chosen in agreement with the species and beam energy. At LISE, gas pressure will be typically 10mbar.

High voltage value for the detector must be also prepares and checks. In order to protect the MWPC, current limit (of few μ A) must be fixed for automatic switch-off the voltage. At LISE for 10mbar isobutene, optimum voltage will around -600V.

During the experiment, any CAVIAR insertion in line must be done with beam off. With beam, observation of dedicated analogical signal to one wire can be done at oscilloscope. In that way we can increase progressively the high voltage until obtain signals like Figure 3.

Then, threshold is applying just higher the noise (~ 13 mV). Using dedicated CAVIAR scaler, we can flag wires with abnormal counting rate. Threshold can be changed individually wire by wire and observed at the oscilloscope (cf. Fig. 4).

In order to verify if the detector tuning is well optimizing, slits just before CAVIAR can be closed at ± 0.1 mm for the primary beam. If more than one wire have signal with a too high statistics, it is an indication that the high voltage and threshold are not satisfying.

With the close slits, we can also determine the center of the CAVIAR detector in the beam line.

We have mention above that CAVIAR is a low interceptive detector. But, energy losses can be observed in the refocusing LISE section. Beams have to be re-centered by decrease the current in the second LISE dipole D32 (cf. Fig. 1). Typically, with fragments at LISE, Bp correction is around 0.5% (in energy, it is around 1%).

DDM16 delays are the same for all CAVIAR logical signals. They are fixed only when Trigger come from the acquisition of the experiment (cf. Fig. 4). CAVIAR memorization is valid when the forehead of rise delay logical signal of CAVIAR is inside the memorization window (cf. Fig. 4, green and blue curves).

Various parameters have to be known or determine in order to reconstruct the mass-to-charge ratio during the experiment. All of these next parameters are used for calculate the nuclide speed and for the nuclide localization on CAVIAR (see appendix for explanation).

- Wire value (W_c) in the beam line center on the horizontal axis. As we have already seen, it is achieved by closing the selection slits at ± 0.1 mm.
- Time of flight (ToF) measurement have to be known from CAVIAR and from the final detection. Absolute calibration must be determined.
- The magnetic rigidity of the first ($B\rho_{D31}$) and the second ($B\rho_{D32}$) section must be known. At LISE, RMN measurement will provide the field gradients. Magnetic rigidities are determined by multiplication of the field by the radius of the dipole.
- Path length (L) between LISE target and CAVIAR and also LISE target and final detection [9].
- The dispersive transport matrix term T16 at the CAVIAR position has to be known. For LISE3 standard optics, we have $T16=16.1\text{mm}/\%$ of $\delta p/p$. We can notice that different optics are available for the LISE spectrometer.

Checks must be done during the experiment. In that way, we take advantage of the various checks out of CAVIAR signals (analog, prompt and delayed signals), memorization window and DDM16 scalers. Spectra produced on line during the experiment like CAVIAR profile and his multiplicity will be also some good additional checks.

EXPERIMENTAL RESULTS

Different tests and experiment have been realized sine 2006. Few of them are now presented.

α -source Measurements

For detector checks, it can be useful to use radioactive α -source emitter (α energies $< 6\text{MeV}$). CAVIAR detector can be inserted between the radioactive source and a Silicon detector. The Silicon junction detector is using for precise energy deposition measurements and simulation the physics detector (like in a real experiment). Electronic treatments to Silicon detector is a classical spectrometry electronic.

We can study α energy losses in CAVIAR and detected in the Silicon detector. Figure 6 present the α energy spectra measured with the Silicon detector for CAVIAR off line, in line with and without gaz. We can observe that α lose almost half of its energy in CAVIAR, contribution of gas is not negligible. Careful calculations using TRIM code [12] have very well reproduced these experimental results. It is important to well understand

contribution of the energy loss in CAVIAR. In real experiment at LISE, we remind that nuclides energies are very high (more than $30\text{MeV}/u$); energies losses in CAVIAR will be around 1%.

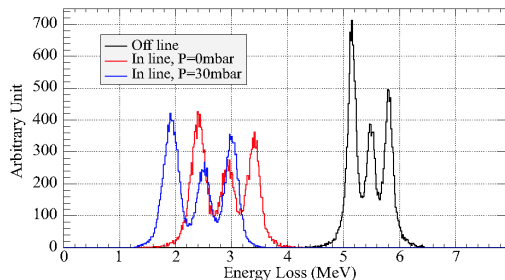

Figure 6: α energy loss in a Silicon detector.

An important parameter is the wires number touched per nuclides pass across CAVIAR. This parameter is the multiplicity. It depends to the beam divergence characteristics, high voltage and threshold. There will also be an impact on the localization accuracy of the nuclide in CAVIAR (cf. Fig. 7).

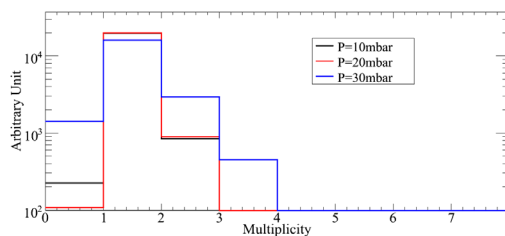

Figure 7: Example of CAVIAR event multiplicity.

Krypton High Energy Beam

An experiment has been realized using a $^{78}\text{Kr}^{33+}$ primary beam at $70\text{MeV}/u$. LISE target was a $500\mu\text{m}$ Beryllium. Heavy ions of high atomic number (here $Z=36$) impose a low gas pressure to 6mbar. High voltage apply to CAVIAR was -513V .

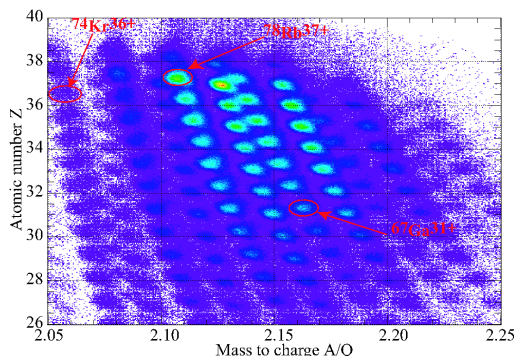

Figure 8: Determination of the atomic number Z as a function of the mass to charge A/Q using CAVIAR.

Experiment has been performed using a Silicon junction at the final focus point in LISE D4. This single detector provides nuclides identification (atomic number Z) by measurements of particles energy losses and time of

flight. Selection slits in the dispersive plane was open at ± 42.5 mm. From the CAVIAR mass to charge reconstruction and the atomic number determination from energy loss in the silicon detector, we can obtain a complete identification of particles (cf. Fig. 8). We can observe that nuclides are well separated. Various nuclides charge states are also identified. Case of heavy ions like Krypton area of the nuclides chart is an extreme case of the CAVIAR contribution. More low ions produce with less charge states will be largely easier for clear separation.

Finally, using contour selection in $Z\%A/Q$ distribution, we can determine the momentum distribution for few nuclides (cf. Fig. 9).

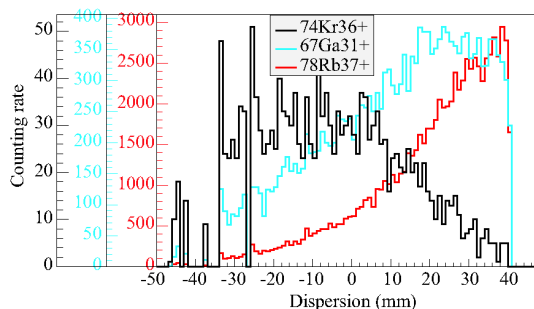

Figure 9: Distribution of selected nuclides in the LISE dispersive plane.

CONCLUSION

In this paper, we have presented the status of the CAVIAR detector at LISE GANIL. This MWPC measure the horizontal position of each fragment in the first dispersive plane of the spectrometer. We can determine precisely the mass to charge ratio of each particle during experiment. Since 2006, various improvement have been done like new preamplifiers, dedicated acquisition system based on VME standard. Some efforts must be done to the cables, connectors and ECM before preamplifiers with the objective of noise reduction. CAVIAR detector offers new possibilities to the LISE spectrometer. It will be certainly an interesting tool for SPIRAL2 beams that will be available 2013.

APPENDIX

We give here formulas for determine the nuclides mass-to-charge A/Q knowing its position in the dispersive plane and its time of flight (see appendix A in ref. [8]).

For each event, we have to determine the average CAVIAR wire (W_a) touched knowing his multiplicity N_{mult} and wires touched W_i : $W_a = \sum W_i / N_{mult}$.

Knowing the central wire W_c , the dispersion is $X_{disp} = W_a - W_c$.

With the LISE magnetic rigidity of the first section ($B\rho_{D31}$) and the matrix dispersive term T_{16} in the plane of CAVIAR, we can determine the single magnetic rigidity $B\rho_w$ like:

$$B\rho_w = B\rho_{D31} \times \left(1 + \frac{X_{Disp}}{T_{16}} \right) \quad (1)$$

Finally, knowing the path length L and the measured time of flight T , we determine the mass-to-charge ratio:

$$\frac{A}{Q} = \frac{B\rho_w \times c}{M_{UMA} \times \beta\gamma} \quad (2)$$

With c the speed light, $\beta=L/(cT)$, γ the Lorentz factor and M_{UMA} the atomic mass unit.

REFERENCES

- [1] R. Anne et al., "The achromatic Spectrometer LISE at GANIL", NIM, A257, (1987), 215-232.
- [2] R. Anne, A.C. Mueller, "LISE3: a magnetic spectrometer-Wien Filter combination for the secondary beam production". NIM, B70 (1995), 276-285.
- [3] R. Anne, "LISE2000", Preprint GANIL, P 02 01
- [4] S. Grévy, R. Hue, "CLIM: the new rotating target for exotic nuclei production at LISE spectrometer", 24th World Conference of the International Nuclear Target Development Society - INTDS2008, Caen: France (2008).
- [5] S.M. Lukyanov et al., "Experimental evidence for the particle stability of ^{34}Ne and ^{37}Na ", J. Phys. G: Nucl. Part. Phys. 28 (2008), L41-L45.
- [6] F. Sauli, "Principles of operation of multiwire proportional and drift chambers", Lectures given in the Academic Training Programme of CERN, CERN 77-09, 3 May 1977.
- [7] R.A. Asaturyan et al. "The Multiwire Proportional Chambers Coordinate System of MULTI Set-Up", Instruments and Experimental Techniques, V 42, N3, 1999, pp 342-346.
- [8] R.A. Astabatyán, "Set-Up on the basics of multiwire proportional and ionization chambers for radioactive beam experiments", Preprint JINR, E13-2002-138, Dubna, 2002.
- [9] L. Perrot, "Le détecteur CAVIAR", Preprint GANIL, R 07 04, HAL: in2p3-00178047, version 1
- [10] W. D. Peterson, "Versa Module Eurocard", VMEbus International Trade Association, USA, 1991. <http://www.vita.com/>
- [11] C. Houarner, L. Olivier "Discriminator Delay Memorization 16 Channels" and "CAVIAR Acquisition System Guide", Preprints GANIL, December 2008, <http://wiki.ganil.fr/gap/wiki/Documentation/VME/DDM16>.
- [12] J. F. Ziegler, J. P. Biersack and U. Littmark, "The Stopping and Range of Ions in Solids", Pergamon Press, New York, 1985 (new edition in 2009).